

Assessment of Under-Frequency Load Shedding in Mongolia Considering Inertia Scenarios

Choidorj Adiyabazar
Power System Analysis and Research
Department
National Dispatching Center Co.,Ltd
Ulaanbaatar, Mongolia
choidorj.a@ndc.energy.mn

J.L. Rueda
Department of Electrical
Sustainable Energy
Delft University of Technology
(TU Delft)
Delft, Netherlands
J.L.RuedaTorres@tudelft.nl

Martha N. Acosta
School of Mechanical and Electrical
Engineering
Universidad Autónoma de Nuevo León
Nuevo León, México
martha.acostamnt@uanl.edu.mx

P. Palenski
Department of Electrical
Sustainable Energy
Delft University of Technology
(TU Delft)
Delft, Netherlands

F. Gonzalez-Longatt
Martha N. Acosta
Department of Electrical engineering,
Information Technology and
Cybernetics
University of South-Eastern Norway
Porsgrunn, Norway
fglongatt@fglongatt.org

Abstract—The Mongolian power system (MPS) has been changing in recent years mainly by the integration of wind power and solar photovoltaic sources which until 2019 has been reached a 20% of the total generation sources. The interconnection with the Russian power system is crucial from the frequency control and stability point of view, especially during the winter, since it provides the necessary power to cover the local energy lack. The importance of this interconnection was evident during the disconnection of the two transmission lines that connect MPS to RPS producing the major frequency event on 29th June 2018, disconnecting 112 MW by the action of the under-frequency load shedding (UFLS) and making more than 1.5 million without electricity that day. The objective of this paper is assessing the existing UFLS schemes installed in the MPS by using numerical time-domain simulations. The disconnection from the RPS is used to evaluate the suitability of the UFLS considering two scenarios: winter high-demand, high-inertia and summer low-demand, low-inertia. Results of this research paper have demonstrated that the actual UFLS scheme is not enough to avoid frequency collapse in real-life conditions during the summer low-demand, low-inertia scenario.

Keywords— Frequency control, frequency stability, Mongolian power system, under-frequency load shedding.

I. INTRODUCTION

The electricity sector in Mongolia is mainly divided into four companies: (i) generation, (ii) transmission, (iii) distribution and (iv) sales (dispatching) of electricity. One of the main concerns in the Mongolian government is the power shortage issues; therefore, they have been adopted ambitious energy policies to address this problem. In 2015 the Mongolian government published State Policy on Energy document, which establishes plans to medium- and long-term targets of energy development [1]. In this document, the perspective of renewable generation capacity will account for 20% and 30% of installed generating capacity by 2020 and 2030, respectively. Currently, in the Mongolian Power System (MPS), approximately 20 per cent of total electricity generated comes from large power plants without highspeed regulation and renewable energy sources.

Furthermore, MPS is typically loaded close to its steady-state stability limit, and the power demand is continuously rising. For these reasons, MPS is more sensitive to system disturbance. The operation at points near to the steady-state

stability limit is a massive risk to MPS stability, i.e., in the event of a disturbance, there is a possibility of cascading events that can lead MPS to total collapse, as occurred in 2012, 2015 and 2018.

The vulnerability of the MPS to under-frequency events, caused by operation at points near to the steady-state stability limit, was reflected in the major frequency event (MFE) occurred on 29th June 2018. During a typical summer day at 23:02:58:90 hours, a strong wind caused a single phase to ground fault in transmission lines 257 and 258, disconnecting the MPS from the RPS. At that time, the total load in MPS was 535 MW, the combined heat and power (CHP) plants and the wind power plants were generating 349.5 MW and 30 MW, respectively. Moreover, the power imported from RPS was 155.5 MW. Consequently, the power deficit in the insolated MPS produced that the frequency dropped quickly, and the emergency under-frequency relays acted. After the under-frequency load shedding (UFLS) activated a minimum frequency of 48.47 Hz was reached, and several minutes later, the frequency was recovered to 49.77 Hz. However, the frequency was under its operational values, $f_0 = 50 \pm 0.2$ Hz, and the operator disconnects several loads resulting in frequency overshoot (see Fig. 1). The total load disconnection was 112 MW affecting around 1.5 million people. This MFE indicated the need to assess the existing UFLS scheme installed in the MPS.

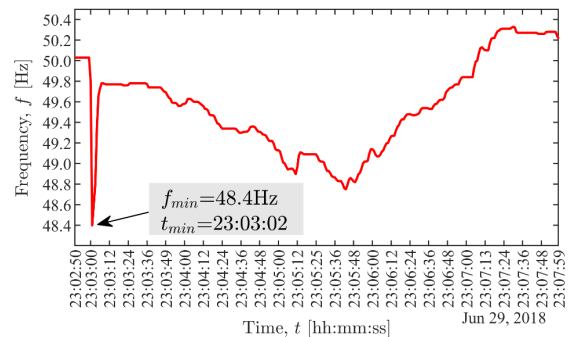

Fig. 1. Plot of frequency from MFE occurred on 29th June 2018 in MPS.

The objective of this paper is assessing the existing UFLS scheme installed in the MPS. As the experience demonstrated in the MFE occurred on 29th June 2018, the sudden disconnection of the 220 kV transmission lines that

interconnect the MPS and the RPS produces the largest loss infeed. Therefore, this MFE is used as system frequency disturbance to assess the UFLS used in the MPS. The impact of that major event in the system frequency response of the MPS is evaluated by using time-domain simulations on the whole real power system model using DIgSILENT® PowerFactory™. Two scenarios are evaluated: winter high-demand, high-inertia and summer low-demand, low-inertia. The main contribution of this paper is to provide the transmission system operator of the MPS an assessment of the actual UFLS scheme by using simulations considering the major loss infeed coming from the disconnection of the RPS. Simulation results in the summer low-demand, low-inertia scenario indicate the UFLS action may lead to frequency instability in the case of a disconnection between the MPS and the RPS at 250 MW power transfer. This paper is organised as follows: in Section II, it is described how is organised the MPS, the power generation capacity and the geographical location of its equipment. Moreover, it is presented the existing UFLS scheme in MPS. Section III presents a description of the methodology followed to assess the existing UFLS scheme. Section IV describes the simulations and results obtained. Finally, Section V presents the conclusion.

II. MONGOLIAN POWER SYSTEM

A. Overview of MPS

The Mongolia electricity sector is an unbundled system divided into generation, distribution, transmission, and dispatch companies. Approximately 85% of the total electricity produced by MPS comes from coal-fired power plants (CFPP). Meanwhile, the remaining 15% is provided by renewable energy sources (RES) including hydro, wind and solar power plants [1].

The MPS supply the electricity through five regional energy systems: (i) *Central energy system* (CES), (ii) *Western energy system* (WES), (iii) *Altai Uliastai energy system* (AUES), (iv) *Eastern energy system* (EES) and (v) *Southern energy system* (SES). Moreover, the MPS is equipped with 20 generation sources (nine thermal power plants, three wind power plants, five solar power plants and three hydropower plants) and the power produced by all generation sources is transferred through 220kV and 110kV overhead transmission lines [1]. The largest regional energy system in the MPS is CES. Its total installed capacity is 1,281 MW of which CHP plants and RES plants covers the 63.5% and 16.5% of peak demand, respectively. The remaining 20% of peak demand is covered by electricity imported from Russian power system (RPS). CES is connected to AUES, EES and SES through 110kV transmission lines and to RPS through 220kV double circuit transmission lines. The mining industry developments in the south Gobi region have been leading to a significant increase in electricity demand in CES, the peak power demand of Oyu tolgoi copper mine was estimated at around 200 MW in 2019 [1]. Meanwhile, WES supply three provinces in the western part of Mongolia with a total demand of 20 MW and it is connected to Russian electricity network through 220 kV double circuit transmission lines. EES covers two provinces in the eastern part of Mongolia with a total demand of 36 MW.

B. Existing UFLS scheme in MPS

The UFLS scheme is a frequency control strategy used in the power system to treat under-frequency events due to a massive loss of generation or an excess of power demand in the power system [2], [3]. The traditional UFLS relay, such as ANSI 81L, has been classified into the category of a fixed number of stages and time delays and has been widely used in power systems. Furthermore, the principal settings in the UFLS relay and thus in the traditional UFLS scheme are [4]: (i) *block size of load shedding* (ΔP_{Shed}) is the amount of load to be dropped at all stages, and this value usually is given in percentage or power unit, (ii) *the number of load shedding stages* (N_s) is an integer value that defines the number of steps to be used to shed the load, (iii) *frequency threshold* (f_r) is a pre-set frequency value at each stage in which load must be shed and (iv) *time delay* (t_d): is an intentional time delay between activating the consecutive stages usually given in seconds or cycles.

The MPS has a decentralised traditional UFLS scheme base on an automatic conventional static UFLS. It uses under-frequency relays (81) based on local measurement at each local placement. Only 85% of the total loads in the MPS are equipped with modern microprocessor-based under-frequency relays. However, it must be noticed that from that 85%, not all the loads are equipped with a rate of change of frequency (*RoCoF*) relays (81R).

The objective of the UFLS scheme in the MPS is to arrest the frequency decaying before reaches its minimum allowable value of 47.0 Hz, to avoid the activation of the under-frequency protection of the generators which are pre-set at 46.0 Hz. Furthermore, the UFLS scheme is designed for a maximum load shedding between 45% and 55% of the MPS total demand. The *frequency threshold* is in a range from 48.8 Hz up to 47.2 Hz and the *number of load shedding stages* are typically nine (the interval and number of the steps could vary from one area to another depending on the typical shape of the load, and the network characteristics, discussion of those details are beyond the scope of this paper). The full settings of the existing UFLS in MPS are described in Table I. The first stage needs to shed a relatively 8% of the load to reduce significantly the rate at which the frequency drops. Once the rate at which the frequency drops is slowed, then it is allowed to trip 5% of load, this setting also helps to prevent a large over-shoot during the frequency recovery period. t_d is adjusted at 0.3 seconds (18 cycles).

TABLE I. SETTINGS OF THE EXISTING UFLS SCHEME IN MPS

Stage	f_r [Hz]	t_d [s]	ΔP_{Shed} [%]
1	48.8	0.3	8.0
2	48.6	0.3	5.0
3	48.4	0.3	5.0
4	48.2	0.3	8.0
5	48.0	0.3	8.0
6	47.8	0.3	5.0
7	47.6	0.3	5.0
8	47.4	0.3	5.0
9	47.2	0.3	5.0

III. METHODOLOGY

The performance of the existing UFLS scheme installed in the MPS is evaluated by analysing the frequency response, using time-domain plots, when a sudden loss of generation occurs in the MPS. Due to synchronous generators of the MPS are not equipped with automatic generation controller. Therefore, the frequency response will be analysed in its more pure and classical primary response [5], and its indicators will be used to assess the existing UFLS scheme. The principal frequency response indicators are [6], [7]: (i) minimum frequency (f_{min}) refers to the minimum value of the frequency during the transient [8], (ii) minimum time (t_{min}) is the time required to reach f_{min} from the moment where the disturbance is inserted in the power system ($t = 0$) [9], (iii) the Rate of Change of Frequency ($RoCoF$) is calculated as the rate of change of the frequency measured by the frequency relays and the unit used is Hz/sec [10]. Finally, (iv) Steady-state frequency (f_{ss}) is the capacity of the power system of recovering from the event is measured by the steady-state frequency; it represents the final value of the frequency when $RoCoF$ is zero [11].

As observed in the analysis of the MFE on 29th June 2018, the MPS is especially sensitive to disconnection from the RPS. Therefore, this event is considered the most critical infeed load, and it is used to test the suitability of the UFLS scheme in the MPS. The power system frequency response is mainly sensible to two parameters: (i) total power imbalance (ΔP) and (ii) the total system inertia (H_{sys}). Moreover, ΔP depends on several factors, particularly in the MPS there are two principal factors: the power transfer (import/export) (P_{tie}) from the RPS and the peak demand (P_L) in the MPS. Due to the total peak demand in the MPS has increased in recent years, as shown in Table II, the maximum power transfer from the RPS has risen slightly to reach the maximum capacity of 250 MW in 2019. The power demand is exceptionally dependent on the time of the day, but also season has a massive impact on electricity consumption (see Fig. 2).

TABLE II. PEAK DEMAND GROWTH IN THE LAST FIVE YEARS, CES

Year	P_L [MW]	P_{tie} [MW]	Peak growth [%]
2015	965	230	0.4
2016	975	245	1.0
2017	1,016	245	4.2
2018	1,115	245	9.9
2019	1,153	250	5.5

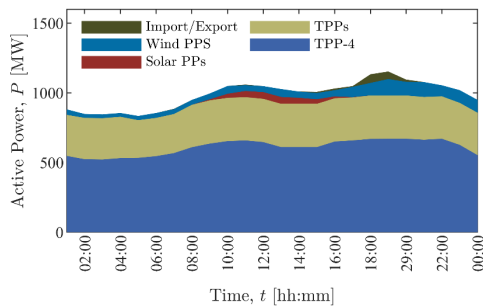

Fig. 2. Daily load profile of Central energy system (CES), during a winter high load period.

The difference between peak load (in the evening) and low night-time load (offload hours) directly depends on the type of consumers and their consumption patterns. During a winter season-high load period, daily electricity demand is about 18.0-23.0 million kWh, and the daily difference between peak and low demand is reaching 280-400 MW. In this paper, two simulation scenarios are considered to assess the UFLS scheme in the MPS:

(i) *Scenario I (Winter High-demand, High-Inertia)*: In the winter season, the demand values are the highest of the year due to temperatures reaching values below -35°C and the central heating systems are working. The peak demand reach values around 1,235 MW at 19:00 hours. Therefore, the MPS works at its maximum capacity generating about 985 MW. Unfortunately, this quantity of generation is not enough to cover the peak demand. Thus the lack of power (around 250 MW) is supplied by the RPS. Since the winter peak demand stresses the generation power plants at the MPS and requires a large number of generation unit on service, the total inertia is maximum $H_{sys} = 5.93\text{s}$ at peak demand, and the total kinetic inertia is $KE_{sys} = 7319.80\text{ MW}\cdot\text{s}$. Peak load forecast of the CES is made based on the load growth of recent years and information of new major end-users to get connected to the grid. In this paper, peak load is considered 1234.8 MW in MPS.

(ii) *Scenario II (Summer Low-demand, Low-Inertia)*: In the summer season, the central heating system is stopped, and the power demand reaches its minimum values approximately 556 MW at 03:00 hours, as a consequence, the generation in the MPS is minimum and the power imported from RPS is 50 MW. Since the demand is minimum, several numbers of large power plants are scheduled to be out the service for maintenance purposes in this season. Therefore, the total inertia reaches its minimum value $H_{sys} = 3.66\text{s}$ at peak demand and the total kinetic inertia is $KE_{sys} = 2402.4\text{ MW}\cdot\text{s}$.

The principal difference of those scenarios is that the inertia is reduced in a significant amount. From KE values are easy to see that there is a reduction of 67.1794% in *Scenario II* concerning *Scenario I*. Therefore, *Scenario II* represents a significant challenge in terms of frequency control, as low values of inertia produce faster and deeper changes in the system frequency. Consequently, the ULFS scheme in MPS will be assessed in the two scenarios mentioned above based on the power transfer from the RPS (P_{tie}) and system inertia. Besides, due to the difference between peak demand and low demand is 30-40% and knowing that the size of the power imbalance depends on the power flow transferred by the interconnection from the RPS to the MPS, three cases are defined to be evaluated in each scenario: *Case 1*: Low importation, $P_{tie} = 50\text{ MW}$, *Case 2*: Average importation, $P_{tie} = 150\text{ MW}$ and *Case 3*: Maximum importation, $P_{tie} = 250\text{ MW}$. Therefore, six different loading conditions result from the combination of scenarios and cases: winter low (I.1), winter medium (I.2), winter peak, (I.3), summer low (II.1), summer medium (II.2) and summer peak (II.3). Table III shows a summary of scenarios and cases defined in this paper.

IV. SIMULATION AND RESULTS

The full dynamic model of MPS has been implemented in DigSILENT[®] PowerFactory[™] to investigate the performance of the existing UFLS scheme in the MPS. The MPS models

implemented in PowerFactoryTM and consists of 61 synchronous generators, three wind power plants, five PV power plants, 7685 terminals, 236 lines and 260 loads. The MPS model included all models required to perform dynamic analysis of electromechanical transients such as governors and automatic voltage regulators (AVR). Moreover, the protection schemes of the MPS consist of 85 UFLS relays, each relay has nine stages, and the settings have been defined based in the MPS specification. These have been verified with the specialised personnel at the field.

TABLE III. SUMMARY OF SCENARIOS AND CASES

Case	Operation time of day	P_{tie} [MW]	Scenario I		Scenario II	
			P_L [MW]	P_{gen} [MW]	P_L [MW]	P_{gen} [MW]
1	03:00	50	838.0	788.5	556.0	506.0
2	12:00	150	1094.8	944.8	656.0	506.0
3	19:00	250	1234.8	984.8	585.0	335.0

The sudden disconnection of the 220 kV transmission lines that interconnect the MPS with RPS creates the most significant infeed loss; therefore, this paper uses this event as system frequency disturbance to assess the existing UFLS scheme. Thus, the disturbance is simulated by the sudden disconnection of transmission lines 257 and 258 at $t = 0$ s; it is done by tripping by main protection. Fig. 3 present a simplified single-line diagram of the MPS, specifically the CES.

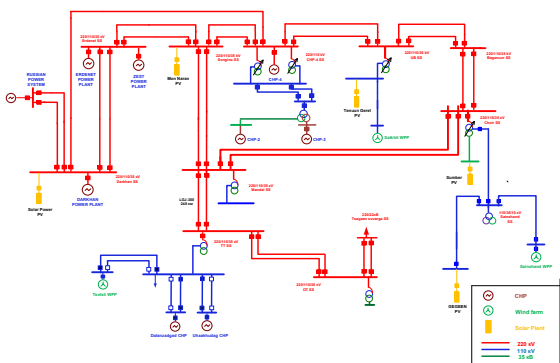

Fig. 3. Simplified single-line diagram of the MPS showing significant components and the interconnector to the RPS.

The settings of the existing UFLS scheme are based on the fact that the MPS should be able to continue operation following a total loss of power up to $P_{tie} = 250$ MW. This represents the simultaneous disconnection of the transmission lines 257 and 258 that interconnect the MPS and the RPS. DIGSILENT[®] PowerFactoryTM is used to simulate the MPS on the considered scenarios and cases. For each simulation, synchronous machines minimum frequency (f_{min}), steady-state frequency (f_{ss}), $RoCoF$ and bus frequency in each load (Measurement $RelFmeans$ in the PowerFactoryTM model of UFLS) were measured over the simulated duration of 100 s. It is essential to mention that the main power plants governor droop settings were tuned by a test of results on the real system.

The existing UFLS scheme is assessed for the scenarios and cases defined in Table III. The MPS has a peak demand of 1234.8 MW in January, and the maximum import power from RPS is 250 MW in the winter peak operation scenario, this represents the worst case in the real system for frequency

stability. The major event is the disconnection of transmission lines 257 and 258 by acting the primary protection. In this case, transmission lines 257 and 258 were disconnected after a delay of around 3.15 seconds, the frequency is dropped to a minimum value of 48.25 Hz, and maximum $RoCoF$ is -0.97 Hz/s. The 1st stage of the UFLS scheme is started when the frequency reaches the value of 48.8 Hz, shedding 90.2 MW, meanwhile, the 2nd stage is started at 48.6 Hz, shedding 43.7 MW and the 3rd stage is started at 48.4 Hz, shedding 40.3 MW. After the action of the UFLS scheme, the frequency is reached to 48.83 Hz. However, that frequency value is insufficiently recovered for acceptable value as well as, in the MPS code is required the normal operating range is 50 ± 0.1 Hz, the frequency deviations of ± 0.2 Hz are allowed for 10 minutes [12]. The 4th stage is not activated since the frequency is recovered from 48.25 Hz and the frequency threshold of the 4th stage is 48.2 Hz as was defined in Table I. The frequency response for Scenario I: Case 1, Case 2 and Case 3 are shown in Fig. 4 and the $RoCoF$ are presented in Fig. 5.

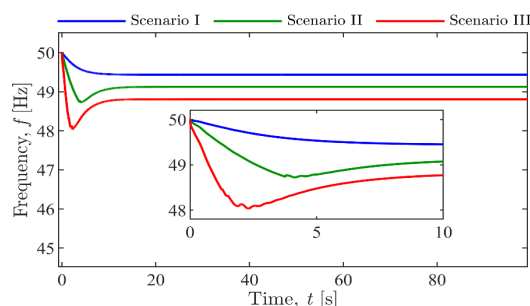

Fig. 4. Scenario I: Frequency response of winter peak operation scenario.

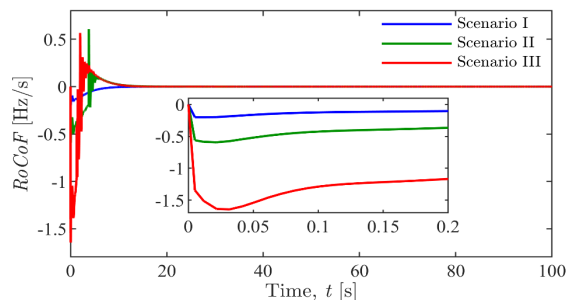

Fig. 5. Scenario I: $RoCoF$ of winter peak operation scenario.

The summary of frequency response indicators for Scenario I: Case 1, Case 2 and Case 3 are presented in Table IV. The frequency response for Scenario II: Case 1, Case 2 and Case 3 is shown in Fig. 6. Moreover, $RoCoF$ is presented in Fig. 7.

TABLE IV. SCENARIO I: FREQUENCY RESPONSE INDICATORS

Case	$RoCoF_{max}$ [Hz/s]	f_{min} [Hz]	t_{min} [s]	Activated stages	P_{Shed} [MW]	f_{ss} [Hz]
1	-0.20	49.44	14.0	—	0.0	49.44
2	-0.59	48.72	4.13	1	90.2	49.14
3	-0.97	48.30	3.41	1, 2, 3	174.2	48.83

In the summer low operation scenario, the total demand is reached to approximately 550-650 MW. At this time, it should be done maintenance in the big thermal power plants due to facilities ageing. Therefore, system inertia is significantly reduced, and the maximum $RoCoF$ is -1.33 Hz/s that is a large

number in the summer low scenario. The maximum $RoCoF$ values from Table V are representing that MPS has low inertia, especially in the summer low operation scenario. The existing UFLS scheme should be designed and tested again under all worst cases. It is noted that the disconnection of load leads to a reduction in both the active and reactive power demand. Therefore, the voltages tend to rise because of UFLS activation; for instance, in Case II.1 and Case II.2, the tensions increase to unacceptable levels. It is recommended that more equipment be switched on SVC and shunt reactor based on bus voltage during the summer scenario.

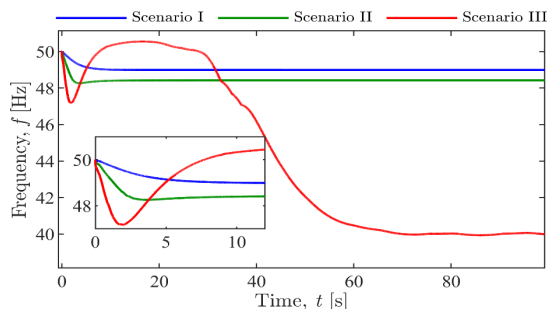

Fig. 6. Scenario II: Frequency response of summer low operation scenario.

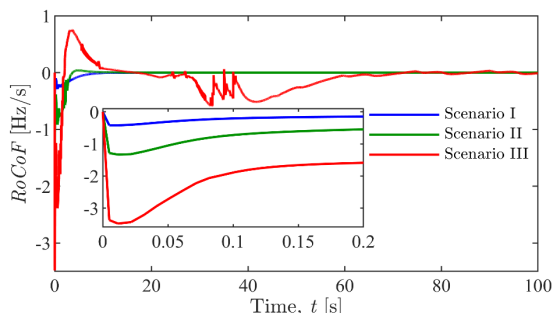

Fig. 7. Scenario II: $RoCoF$ of summer low operation scenario

TABLE V. SCENARIO II: FREQUENCY RESPONSE INDICATORS

Case	$RoCoF_{max}$ [Hz/s]	f_{min} [Hz]	t_{min} [s]	Activated stages	P_{Shed} [MW]	f_{ss} [Hz]
1	-0.42	48.99	12.41	-	0	48.99
2	-1.33	48.19	3.66	1,2,3	114.7	48.51
3	-3.48	47.09	1.90	All stages	315.9	Frequency unstable

V. CONCLUSION

This paper has assessed the existing UFLS schemes for isolated MPS where is particularly sensitive to power imbalances, and UFLS schemes are vital to prevent frequency collapse. The existing UFLS scheme can act when happening a lack of power in winter peak or summer low cases due to UFLS schemes have been designed using approaches of conventional schemes principally decentralised based on local measurement and decisions. The renewable energy sources have an impact on the inertia of the power system, which in trend impacts the $RoCoF$ and therefore the capability of UFLS schemes to act when an outage or loss of interconnection lines occur. The Mongolian grid has already met 20% of the power of renewable energy sources by 2020, and it will have a significant impact on the $RoCoF$ and operation of the existing UFLS scheme. Therefore, UFLS scheme must be designed

using the WAMS-based accuracy real data, since 29 phasor measurement units were installed at critical points in the MPS in January 2020. As a result, the frequency behaviour can be measured more accurately in each important bus as well as, the dynamic model of DiGSILENT® PowerFactory™ can be improved by based on full real data. This new design approach, combined with an optimal setting of the UFLS scheme, can be proposed to be implemented in MPS.

ACKNOWLEDGMENT

Mr Choidorj Adiyabazar, wants to acknowledge the financial support given by National Dispatching Center of Mongolia Co., Ltd. Ms Martha N. Acosta acknowledges the financial support provided by CONACYT (México) and the support of Universidad Autónoma de Nuevo León. Ms Martha N. Acosta and Choidorj Adiyabazar recognise the support of the University of South-Eastern Norway. Prof F. Gonzalez-Longatt would like to express his gratitude to DiGSILENT GmbH for supporting his research.

REFERENCES

- [1] S. Profileprojections, C. Generation, R. Energy, and C. Expansion, "Strategy for NAPS Technical Assistance for Mongolia - RENEWABLE ENERGY CAPACITY EXPANSION PLAN," no. MARCH, 2018.
- [2] Y. R. Omar, I. Z. Abidin, S. Yusof, H. Hashim, and H. A. Abdul Rashid, "Under Frequency Load Shedding (UFLS): Principles and implementation," in *PECon2010 - 2010 IEEE International Conference on Power and Energy*, 2010, pp. 414–419.
- [3] H. Bevrani, *Robust Power System Frequency Control*, Second Edi. Cham: Springer International Publishing, 2014.
- [4] F. Gonzalez-Longatt, "Impact of synthetic inertia from wind power on the protection/control schemes of future power systems: Simulation study," in *IET Conference Publications*, 2012, vol. 2012, no. 593 CP.
- [5] F. Sanchez, J. Cayenne, F. Gonzalez-Longatt, and J. L. Rueda, "Controller to enable the enhanced frequency response services from a multi-electrical energy storage system," *IET Gener. Transm. Distrib.*, vol. 13, no. 2, pp. 258–265, Jan. 2019.
- [6] H. R. Iswadi, R. J. Best, and D. J. Morrow, "Irish power system primary frequency response metrics during different system non synchronous penetration," in *2015 IEEE Eindhoven PowerTech, PowerTech 2015*, 2015.
- [7] A. Mujcinagic, M. Kusljagic, and J. Osmic, "Frequency Response Metrics of an Interconnected Power System," in *2019 54th International Universities Power Engineering Conference, UPEC 2019 - Proceedings*, 2019.
- [8] H. Chamorro, F. Gonzalez, K. Rouzbehi, R. Sevilla, H. Chavez, and V. Sood, "Innovative Primary Frequency Control in Low-Inertia Power Systems Based on Wide-Area $RoCoF$ Sharing," *IET Energy Syst. Integr.*, Feb. 2020.
- [9] F. A. Alshehri *et al.*, "Generic Model of PEM Fuel Cells and Performance Analysis in Frequency Containment Period in Systems with Decreased Inertia," in *IEEE International Symposium on Industrial Electronics*, 2019, vol. 2019-June, pp. 1810–1815.
- [10] H. R. Chamorro, I. Riaño, R. Gerndt, I. Zelinka, F. Gonzalez-Longatt, and V. K. Sood, "Synthetic inertia control based on fuzzy adaptive differential evolution," *Int. J. Electr. Power Energy Syst.*, vol. 105, pp. 803–813, Feb. 2019.
- [11] F. Gonzalez-Longatt, J. Rueda, and E. Vázquez Martínez, "Effect of Fast Acting Power Controller of Battery Energy Storage Systems in the Under-frequency Load Shedding Scheme," in *International Conference on Innovative Smart Grid Technologies (ISGT Asia 2018)*, 2018.
- [12] National Dispatching Center on Mongolia, "Grid Code," pp. 1–349, 2019.