

# Optimal UFLS Settings: An Assessment of Frequency System Response Indicators

Martha N. Acosta

*School of Mechanical and Electrical Engineering*  
*Universidad Autónoma de Nuevo León*  
Nuevo León, México  
[martha.acostamnt@uanl.edu.mx](mailto:martha.acostamnt@uanl.edu.mx)

J.L. Rueda

*Department of Electrical Sustainable Energy*  
*Delft University of Technology (TU Delft)*  
Delft, Netherlands  
[J.L.RuedaTorres@tudelft.nl](mailto:J.L.RuedaTorres@tudelft.nl)

Choidorj Adiyabazar

*Power System Analysis and Research Department*  
*National Dispatching Center Co.,Ltd*  
Ulaanbaatar, Mongolia  
[choidorj.a@ndc.energy.mn](mailto:choidorj.a@ndc.energy.mn)

P. Palenski

*Department of Electrical Sustainable Energy*  
*Delft University of Technology (TU Delft)*  
Delft, Netherlands

F. Gonzalez-Longatt

Martha N. Acosta  
*Department of Electrical engineering, Information Technology and Cybernetics*  
*University of South-Eastern Norway*  
Porsgrunn, Norway  
[fglongatt@fglongatt.org](mailto:fglongatt@fglongatt.org)

**Abstract**— This paper investigates the positive changes in the system frequency response indicators caused by the implementation of a set of optimal settings of an under-frequency load shedding (UFLS) scheme. The optimal UFLS scheme is optimised by minimising the total amount of load shedding and considering the recovery process of the system frequency into its operational values after several losses of generation and satisfies the requirements of the UFLS standard (PRC-006-SERC-02). The idea of implementing the optimal UFLS scheme is to identify how changes the minimum frequency, minimum time, rate of change of frequency and steady-state frequency when the amount of load shedding change. The optimal UFLS scheme formulation starts with identifying the variables to control with the optimisation and its respective bounds. Then, the objective function is formulated in terms of the total load shedding, and finally, the restrictions and requirements of the systems are written as inequality constraints. The optimal UFLS is evaluated in the IEEE 39-bus system. The simulations results demonstrate the suitability of the optimal UFLS to improve the frequency response indicators.

**Keywords**— *frequency control, frequency response indicators, optimisation, under-frequency load shedding.*

## I. INTRODUCTION

The frequency stability is concerned with the ability of a power system to supply its load after a disturbance involving a generation-load imbalance at a frequency within an acceptable range [1]. The sudden disconnection of large generation units causes a significant power imbalance between the power generation and the load demand. This active power imbalance produces a fast drop in the system frequency generated by the deficit of power supply [2]. If the control actions are not appropriately designed, the frequency can drop to values considered unacceptable or even trip a cascade event putting the power system in risk of instability and subsequent blackout. Moreover, if the system frequency reaches unacceptably low values, there is a small-time window to implement emergency actions. If the size of the system frequency disturbance is large, the scheduled power reserve may not be enough to restore the frequency and the power system operators may use emergency control and protection schemes to maintain power system frequency [3]. An emergency control plan used by years is the well-known *under-frequency load shedding* (UFLS). The UFLS strategy is designed to balance the demand for electricity with the supply rapidly and to avoid cascading power system failure [4]. It is essential to coordinate the UFLS with under-frequency

protection of the generator. Premature generator tripping, before system load shedding is complete, can lead to unnecessary system collapse [5]. The situation of frequency control and stability and the problem of adequate settings of UFLS is becoming more complicated with the increased penetration of renewables generation sources [6].

The primary objective of UFLS schemes is to arrest frequency dropping in due time by shedding an appropriate amount of load, in order to recover the frequency into its nominal values [7]. Ideally, the UFLS must act as the primary option and by doing so, preventing the action of generation-side under-frequency protections, which would finally lead to a cascading power outage [8]. In the traditional UFLS schemes, the settings of the UFLS relays are mainly based on the power system operator's knowledge of the power system performance during major frequency events. However, although the frequency is recovered into its nominal values, the UFLS settings are not optimal, and they end up disconnecting more load than necessary.

The UFLS is becoming a very attractive research topic in recent time to deal with several problems related to extremely reduced inertia scenarios, the market pressure to minimise the reserve margins and the operating the tie-line near to the limit of capacities. Many different approaches are reported in the scientific literature. [9] combines UFLS with online fuzzy control strategy to reduce the load shedding value, [10] uses wide area measurements system (WAMS) in combination with under-frequency and under-voltage schemes to recover the frequency and voltage. Furthermore, [11] proposed an artificial neuronal network for estimating the amount of power imbalance in the grid. [12] recommend a method to compute the optimal values of load shedding, frequency threshold and time delay considering the high penetration of renewable generation resources. [13] proposes an adaptative UFLS model based on WAMS information to set up an emergency load shedding strategy and [14] depict a method for assess the optimal load capacity and load disconnection sequence during a power system emergency. The limitation of previous optimization applications is that it assumes all UFLS relay has the same parameters and is no clear in which load is implemented the UFLS.

The limitation of most of the previous methodologies is that it assumes the settings are the same for all relays. This assumption can affect the total amount of load shedding since the amount of load shedding that each relay active depend on

the load value even when all relays have the same settings. The propose of this paper is to investigate the positive changes in the system frequency response indicators caused by the implementation of an optimal setting of a UFLS scheme. An optimal calculation process of the settings of the UFLS improves the power system reliability by minimising the unnecessary excessive load shedding and prevent the operation of under-frequency protections of the synchronous generator. However, this research paper introduces the problem of optimal settings of UFLS relayed using mathematical optimisation. Then, the methodology is used to set the UFLS parameters on a test system, and the principal motive is to determinate how the optimal settings impact the frequency response indicators: minimum frequency, minimum time, rate of change of frequency and steady-state frequency. This paper is organised as follows: in Section II, the methodology to calculate the optimal UFLS scheme is described. Section III presents a description of the test system and the cases defined for assessing the UFLS scheme. Section IV describes the results obtained and present the main observations of the results. Finally, Section V presents the conclusion.

## II. OPTIMAL UFLS SCHEME FORMULATION

The UFLS is explicitly dedicated to deal with under frequency events where there is a lack of generation or an excess of power demand. This section is dedicated to formulating the UFLS scheme as an optimization problem.

### A. Metrics: Frequency response

The frequency response of a power system is typically analysed by using time-domain plots of the system frequency when the major event is applied, and its indicators are (see Fig. 1): the minimum frequency ( $f_{min}$ ) is the resulting value of the difference between nominal frequency ( $f_0$ ) and the maximum frequency deviation ( $\Delta f_{max}$ ), i.e.,  $f_{min} = f_0 - \Delta f_{max}$ . The minimum time ( $t_{min}$ ) is the time at which the frequency reaches its minimum value and its maximum deviation. Moreover, the Rate of Change of Frequency ( $RoCoF$ ) represents the speed at which the frequency changes, i.e., the amount of frequency change in one second,  $RoCoF = df/dt$  [Hz/s]. Finally, the steady-state frequency ( $f_{ss}$ ) denotes the frequency value at which the  $RoCoF$  is zero. This value is typically reached after the inertia response and the governor action [4]-[12-13].

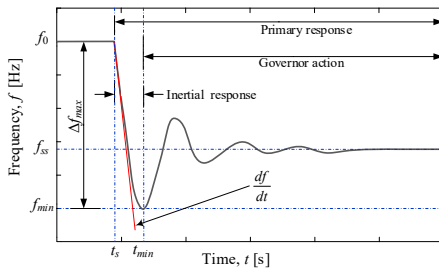

Fig. 1. Frequency response metrics ( $f_{min}$ ,  $t_{min}$ ,  $RoCoF_{max}$  and  $f_{ss}$ ).

### B. UFLS Settings

UFLS relays are used to protect the system and keep the frequency of the system close to the nominal value shedding some of the system load. UFLS relays can be classified into two categories[15]: (i) Fixed number of stages and time delays and (ii) Adaptative number of stages and variable shed demands. The traditional UFLS relay (such as ANSI 81L) falls in the first category and is extensively used in power systems.

In this research paper, the UFLS relays are considered to have a fixed number of stages, but the setting will be optimised in the next subsections. Traditional UFLS scheme relies basically on four main settings: (i) block size of the dropped load ( $\Delta P$ ) defines the amount of load to be dropped at all stages, (ii) the number of stages ( $N_S$ ) is an integer value that denotes the number of steps in which the load will be dropped, (iii) the frequency setpoint ( $f_{sp}$ ) is a pre-set frequency value at which the load must be shed in each stage and (iv) the time delay ( $t_d$ ) between activating the consecutive stages.

### C. Optimisation Problem Definition

The process to formulate the optimal settings of UFLS scheme in this paper is based in the following steps: First, the appropriate set of control variables are identified, those variables are selected to control the frequency response following a system frequency disturbance at the time the optimisation considered the main aspects of the UFLS relay features and respective bounds are defined for the relay settings. Then, the objective function to be minimised was written in terms of the control variables, and finally, the restrictions and requirements of the systems are written as inequality constraints. The full procedure of each step is described below.

#### 1) Variables

The control vector ( $\mathbf{x}$ ) is a vector used to specify the control variables to be used in the optimisation process:

$$\mathbf{x} = [\Delta P_{ij} \quad f_{sp,j}^1 \quad \Delta f_{sp,kj}]^T, \quad \begin{cases} i = 1, \dots, N_S \\ j = 1, \dots, N_R \\ k = 1, \dots, N_S - 1 \end{cases} \quad (1)$$

where  $\Delta P_{ij}$  is the percentage load shedding of the  $i$ -th stage in the  $j$ -th UFLS relay,  $f_{sp,j}^1$  is the first frequency setpoint of the  $j$ -th UFLS relay and  $\Delta f_{sp,kj}$  represents the interval between two subsequent frequency setpoints. Moreover,  $N_R$  is the number of UFLS relays installed in the power system, and  $N_S$  is the number of load shedding stages in each relay.

The control variables are bounded by its upper ( $u$ ) and lower ( $l$ ) allowable values as follows:

$$\begin{aligned} \Delta P_l &\leq \Delta P_{ij} \leq \Delta P_u \\ f_{sp,l}^1 &\leq f_{sp,j}^1 \leq f_{sp,u}^1 \\ \Delta f_{sp,l} &\leq \Delta f_{sp,kj} \leq \Delta f_{sp,u} \end{aligned} \quad (2)$$

where  $\Delta P_l$  and  $\Delta P_u$ , represents the minimum and maximum permissible percentage of load shedding, respectively.  $f_{sp,l}^1$  and  $f_{sp,u}^1$  are the minimum and maximum limit frequency setpoint in the first stage, respectively. Moreover,  $f_{sp,l}^1$  and  $f_{sp,u}^1$  are the minimum and maximum values allowed for  $\Delta f_{sp}$ .

#### 2) Objective function

The idea of optimising the settings of the UFLS relays is to reduce, as much as possible, the amount of load shedding during the under-frequency event. Consequently, the purpose of the UFLS optimisation is determinate the minimum amount of load shedding required to recovers the steady-state frequency into its operating values. Therefore, the objective function is formulated as the sum of all active stages in each UFLS relay multiplied by active power in its respective load. The objective function is defined as follows:

$$f(\mathbf{x}) = \min \left( \sum_{j=1}^{N_R} \sum_{i=1}^{n_s} \Delta P_{ij} P_j \right) \quad (3)$$

where  $P_j$  is the active power of the  $j$ -th load with UFLS relay and  $n_s$  is the number of activated stages.  $n_s$  is different from  $N_s$  ( $n_s \leq N_s$ ).

### 3) Constraints

The objective function defined in (3) is subject to certain restrictions to ensure the security of the power system and fulfil the technical requirements of the utility companies:

a) *Steady-state frequency ( $f_{ss}$ )*: after a massive loss of generation, the  $f_{ss}$  must remain inside the operating range of the synchronous generators, i.e.,  $f_{ss}^{\min} \leq f_{ss} \leq f_{ss}^{\max}$ . This restriction is formulated as two inequality constraints as follow

$$\begin{aligned} g_1(\mathbf{x}) &= f_{ss} - f_{ss}^{\max} \leq 0 \\ g_2(\mathbf{x}) &= f_{ss}^{\min} - f_{ss} \leq 0 \end{aligned} \quad (4)$$

b) *Frequency setpoint ( $f_{sp}$ )*: the  $f_{sp}$  in each stage of the UFLS relays shall be inside the limits defined by the technical requirements of the utility companies, i.e.,  $f_{sp}^{\min} \leq f_{sp} \leq f_{sp}^{\max}$ . Since the optimisation gives the first  $f_{sp}$  of each relay and it is already bounded, it is necessary to define the inequality constraint for the minimum limit as follows:

$$g_3(\mathbf{x}) = f_{sp}^{\min} - f_{sp,ij} \leq 0 \quad (5)$$

## III. CASE STUDY DEFINITION

To investigate the positive changes in the system frequency response indicators caused by the implementation of an optimal setting of a UFLS scheme, the classical IEEE 39-bus system is used. In this test system, generator G1 represents the aggregation of several. The original model data come from the book titled ‘‘Energy Function Analysis for Power System Stability’’ [16]. The test system has been implemented in DlgSILENT® PowerFactory™ 2020. The schematic single line diagram of the test system is shown in Fig. 2. The test system consists of ten generators, 19 loads, 34 transmission lines, 12 transformers and 39 buses. The total active power generation is 6,140.81 MW, and the total power demand is 6097.10 MW [17]. The frequency response of the test system is excited by a frequency event, in this case, the sudden disconnection of generators G1 and G9 at  $t = 1.0$ s, these generators represent a loss of a generation of 29.8% of the total generation,  $\Delta P = P_{G1} + P_{G9}$ . The UFLS relays are installed in all loads. In this paper, the 19 UFLS relays ( $N_R = 19$ ) has four load shedding stages ( $N_S = 4$ ). The time delay was set as  $t_d = 0.20$ s. The generators causing the disturbance (G1 and G6) are highlighted with red colour, and the loads where the UFLS relays are installed are marked with blue colour in Fig. 2.

Three cases are defined: *Case I* refers to the natural frequency response of the IEEE-39 bus system without any UFLS scheme. *Case II* study the frequency response of the test system considering the UFLS but using a traditional setting. Finally, *Case III* represents the frequency response of the test system, considering the optimal settings of the UFLS scheme defined in Section II. For all cases, it is observed the indicators of the frequency response: (i)  $f_{min}$ , (ii)  $t_{min}$ , (iii)  $RoCoF_{max}$  and (iv)  $f_{ss}$ .

Due to the IEEE-39 bus system is representative of the North American system, the parameters of the UFLS relays must satisfy the SERC (South-eastern Electric Reliability Council) UFLS Standard: PRC-006-SERC-02 [18]: (i)  $f_{ss}$  shall

be between 59.5 Hz and 60.5 Hz, (ii)  $f_{sp}$  shall be no lower than 58.4 Hz and not higher than 59.5 Hz, (iii)  $\Delta f_{sp}$  shall be at least 0.2 Hz but no greater than 0.5 Hz and (iv)  $t_d$  shall be at least six cycles (0.1sec).

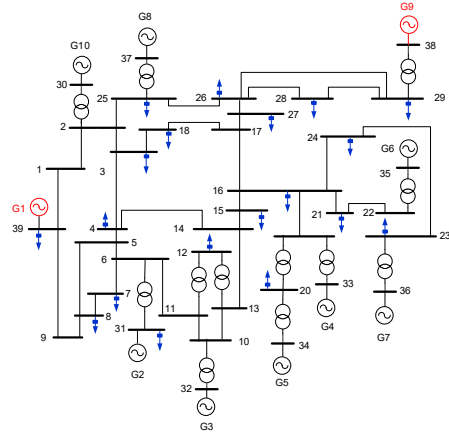

Fig. 2. Descriptive single-line diagram of the IEEE-39 bus system.

*Case I (No UFLS scheme)*: In this case, it is presented the dynamic response of the frequency when the disturbance occurs by disconnecting the generators G1 and G9, and there is not a UFLS scheme installed.

Fig. 3 shows the frequency response measured in all buses. The inertia response acts to try to stop the frequency drop since there is not installed a UFLS scheme in the IEEE-39 bus system. Despite the action of the inertia response, the frequency drop cannot be arrested and continues dropping reaching values below the minimum allowable frequency and causing that the system becomes unstable. The minimum permissible frequency in 60 Hz nominal frequency, is defined by the under-frequency relays settings of the synchronous generators that typically operates if the frequency reach vales from 58.4 Hz to 57.9 and the frequency does not recover within 30 seconds [19].

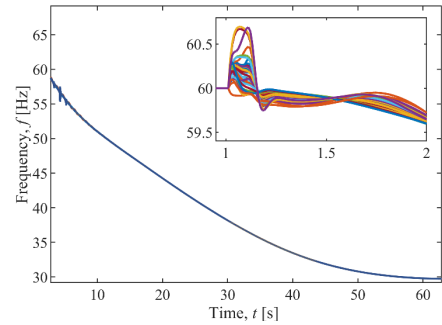

Fig. 3. *Case I (No UFLS scheme)*: Frequency response measured in the 39 buses after the disconnection of generators G1 and G9.

Meanwhile, Fig. 4 shows the  $RoCoF$  of all buses, the maximum  $RoCoF$  produced by the disconnection of generators G1 and G9 is presented in bus 29, and its value is  $RoCoF_{max} = 32.885$ Hz/s at 1.012s. The high amount of the  $RoCoF$  is due to significant generation deficiency, i.e., the disconnection of generators G1 and G9 represents almost 30% of the total generation, and this size of the loss of generation causes that the total system inertia decreases. From the results in *Case I*, it is evident that the power system requires a UFLS scheme to arrest the frequency drop and avoid the activation of the under-frequency relays that protect the synchronous generators. Moreover, a UFLS scheme is needed to recover

the frequency into the established  $f_{ss}$  limits, i.e.,  $59.5 \leq f_{ss} \leq 60.5$ .

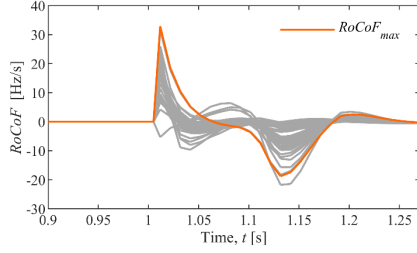

Fig. 4. *Case I (No UFLS scheme)*: RoCoF measured in the 39 buses after the disconnection of generators G1 and G9.

*Case II (Traditional UFLS scheme)*: This case presents the frequency response when a traditional UFLS scheme is implemented on all loads installed on the IEEE-39 bus system. The settings of the installed UFLS relays are selected to fulfil the requirements of the SERC UFLS Standard. The settings are presented in Table I. The block size of the dropped load ( $\Delta P$ ) of each *Stage* are chosen such that the total load shedding covers the loss of generation, i.e.,  $\Delta P = P_{G1} + P_{G9}$ . Moreover, the minimum frequency does not take values below 58.4 Hz.

TABLE I. UFLS RELAYS SETTINGS USING CASE II (TRADITIONAL UFLS SCHEME)

Stage	$\Delta P$ (%)	$f_{sp}$ (Hz)	$\Delta f_{sp}$ (Hz)	$t_d$ (s)
1	15	59.3	0.3	0.2
2	10	59.0	0.3	0.2
3	10	58.7	0.3	0.2
4	5	58.4	0.3	0.2

*Case III (Optimal UFLS scheme)*: shows the frequency response when the optimal UFLS scheme is used to obtain the parameters of the UFLS relays previously installed in the 19 loads. The settings obtained from the optimal UFLS scheme are described in Table II.

The convergence curve of the objective function defined in (3) after being evaluated 3,000 times is presented in Fig. 5. It is observed from iteration 2,351 the value of the objective function remains constant at  $\Delta P = 1,768.79$  MW; this indicates that the objective function reaches its minimum value and fulfil the constraints defined in Section II.C.3).

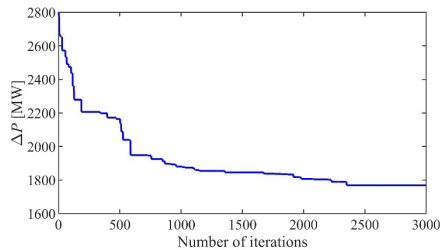

Fig. 5. Convergence curve of the optimal UFLS scheme. *Case III*.

From Table II, it can be observed that the settings are for the first and second stage of all relays, except relay in Load 24 that also has settings for third stage and relay in Load 29 has settings only for the first stage. These results mean that it is only required to activate those stages to ensure the frequency recovering and fulfil the inequality constraints defined in (4). Furthermore, it is given the frequency setpoint of each stage, and those values satisfy the inequality constraint defined in (5)

which determine that frequency setpoint must be  $58.4 \leq f_{sp} \leq (59.5-59.3)$ .

TABLE II. UFLS RELAYS SETTINGS USING CASE III (OPTIMAL UFLS SCHEME)

Relays Location	$\Delta P$ (%)			$f_{sp}$ (Hz)		
	Stage 1	Stage 2	Stage 3	Stage 1	Stage 2	Stage 3
Load 03	22.02	3.35	---	59.40	58.93	---
Load 04	0.19	11.78	---	59.43	59.10	---
Load 07	4.68	4.75	---	59.31	58.91	---
Load 08	6.40	0.09	---	59.44	59.06	---
Load 12	13.23	2.27	---	59.31	58.89	---
Load 15	19.69	11.25	---	59.44	59.00	---
Load 16	53.51	11.25	---	59.38	59.01	---
Load 18	48.85	5.38	---	59.45	59.01	---
Load 20	32.56	0.05	---	59.34	59.02	---
Load 21	16.02	19.09	---	59.49	59.13	---
Load 23	18.81	1.69	---	59.41	59.15	---
Load 24	48.72	46.60	4.68	59.42	59.20	58.99
Load 25	44.51	48.25	---	59.47	59.06	---
Load 26	36.82	48.59	---	59.45	59.07	---
Load 27	15.94	2.38	---	59.39	58.90	---
Load 28	26.05	3.20	---	59.46	59.01	---
Load 29	17.21	---	---	59.37	59.02	---
Load 31	36.81	18.87	---	59.35	59.00	---
Load 39	0.01	0.29	---	59.45	59.04	---

#### IV. RESULTS AND DISCUSSION

The dynamic simulation of the IEEE-39 bus system to evaluate the three cases defined above are presented in this section. The frequency response of *Case I*, *Case II* and *Case III* is shown in Fig. 6.

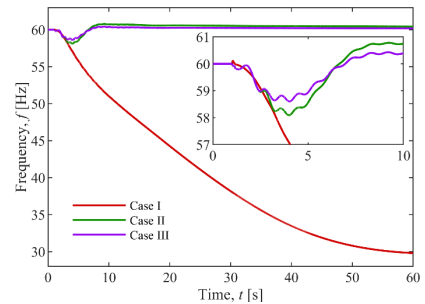

Fig. 6. Frequency response for *Case I*, *Case II* and *Case III* after the disconnection of generators G1 and G9.

The changes in the frequency depending on whether there is installed a UFLS scheme. *Case I* represent the worst case since there is not installed a UFLS scheme in the IEEE-39 bus system and therefore only the inertia response tries to stop the frequency drop. Despite the action of the inertia response, the frequency drop cannot be arrested, and the system becomes unstable. On the other hand, *Case II* improve the frequency response by reducing the  $f_{min}$ ,  $t_{min}$  and recovering  $f_{ss}$  inside the established operating values. Moreover, it showed how it is

improved the frequency response when it is optimised the total load shedding in *Case III*. The frequency response indicators and the total load shedding are summarised in Table III.

TABLE III. FREQUENCY RESPONSE INDICATORS AND TOTAL LOAD SHEDDING FOR CASE I, CASE II AND CASE III

Case	$f_{min}$ (Hz)	$t_{min}$ (s)	$RoCoF_{max}$ (Hz/s)	$f_{ss}$ (Hz)	$\Delta P$ (MW)
I	values below 58.4 Hz at 3.062s		-32.885	Frequency instability	—
II	58.092	3.995	-32.885	60.365	2438.84
III	58.602	4.020	-32.885	60.157	1768.79

In *Case I*, the frequency cannot be recovered by the inertia response and governor action taking values below the 58.4 Hz at 3.062s. This frequency value is outside of the  $f_{ss}$  limits and reaches the frequency setpoint of the under-frequency protection of generators. Therefore, low-frequency values cause the system to become unstable. In contrast, when the UFLS scheme is implemented, the frequency responds indicators depend on the UFLS relays settings. In *Case II*, the minimum frequency and minimum time are reached at  $f_{min}=58.092\text{Hz}$  and  $t_{min}=3.995\text{s}$ , respectively. Furthermore, the four stages were activated for all UFLS relays, and the load shedding is  $\Delta P=2438.84\text{MW}$  which represents 40% of the total load. Thus, the steady-state frequency is improved and is  $f_{ss}=60.365\text{ Hz}$ . Meanwhile, using the settings obtained from *Case III*, the values of the minimum frequency and minimum time is at  $f_{min}=58.602\text{Hz}$  and  $t_{min}=4.020\text{s}$ , respectively. In this case,  $f_{min}$  is improved by 0.88% concerning *Case II*. In this case, *Stage 1* is activated in all UFLS relays, *Stage 2* is not activated only the UFLS relay installed in Load 29, and *Stage 3* is just activated in the relay installed in Load 24. Moreover, the load shedding is  $\Delta P=1768.79\text{MW}$ , which represents 29% of the total load, and it decreases 11% whit respect *Case II*. Furthermore, the steady-state frequency remains inside the established limits, and its value is  $f_{ss}=60.157\text{ Hz}$ .

## V. CONCLUSIONS

The main observations obtained from this research paper are the implementation of UFLS scheme in the power system is essential since it can avoid a possible frequency instability due to significant loss of generation event. Besides, the optimal settings in the UFLS scheme prevent an unnecessary load shedding since the total load shedding amount decrease significantly concerning the traditional UFLS scheme. Moreover, it is demonstrated that the impact of minimising the total amount of load shedding is directly reflected in the frequency response indicators. Thus, these indicators were improved by using the optimal UFLS scheme. The minimum frequency value as well as the maximum frequency deviation value decrease when the optimal UFLS scheme is implemented in contrast with the traditional UFLS scheme. Furthermore, the steady-state frequency in both cases is recovered inside predefined values, and the amount of load shedding does not impact the maximum  $RoCoF$ . However, its value increases depending on the size of the loss of generation since the total system inertia diminish.

## ACKNOWLEDGMENT

Ms Martha N. Acosta would like to acknowledge the financial support given by CONACYT (México), and the support of University of South-Eastern Norway and Universidad Autónoma de Nuevo León. Mr Choidorj

Adiyabazar wants to acknowledge the financial support given by National Dispatching Centre of Mongolia Co., Ltd. and the University of South-Eastern Norway. Prof F. Gonzalez-Longatt would like to express his gratitude to DIgSILENT GmbH for supporting his research.

## REFERENCES

- [1] P. Kundur *et al.*, "Definition and Classification of Power System Stability IEEE/CIGRE Joint Task Force on Stability Terms and Definitions," *IEEE Trans. Power Syst.*, vol. 19, no. 3, pp. 1387–1401, Aug. 2004.
- [2] F. Gonzalez-Longatt, "Impact of synthetic inertia from wind power on the protection/control schemes of future power systems: Simulation study," in *IET Conference Publications*, 2012, vol. 2012, no. 593 CP.
- [3] H. Bevrani, *Robust Power System Frequency Control*, Second Edi. Springer International Publishing, 2014.
- [4] F. Gonzalez-Longatt, F. Sanchez, and Rujiroj Leelaruj, "Unveiling the Character of the Frequency in Power Systems," in *IEEE-PES GTD Grand International Conference & Exposition Asia 2019 (IEEE-PES GTD Asia 2019)*, 2019.
- [5] IEEE, *IEEE Std C37.117 - IEEE Guide for the Application of Protective Relays Used for Abnormal Frequency Load Shedding and Restoration*, no. August. 2007.
- [6] F. Sanchez and F. Gonzalez-Longatt, "Optimization of Frequency Controller Parameters of a BESS by considering Rate of Change Constraints," in *2019 IEEE Milano PowerTech, Powertech 2019*, 2019.
- [7] Y. R. Omar, I. Z. Abidin, S. Yusof, H. Hashim, and H. A. Abdul Rashid, "Under Frequency Load Shedding (UFLS): Principles and implementation," in *PECon2010 - 2010 IEEE International Conference on Power and Energy*, 2010, pp. 414–419.
- [8] L. Sigrist, L. Rouco, and F. M. Echarren, "A review of the state of the art of UFLS schemes for isolated power systems," *Int. J. Electr. Power Energy Syst.*, vol. 99, no. September 2017, pp. 525–539, 2018.
- [9] B. Huang, Z. Du, Y. Liu, and F. Zhao, "Study on online under-frequency load shedding strategy with virtual inertia control of wind turbines," *J. Eng.*, vol. 2017, no. 13, pp. 1819–1823, 2017.
- [10] J. Wang, H. Zhang, and Y. Zhou, "Intelligent under Frequency and under Voltage Load Shedding Method Based on the Active Participation of Smart Appliances," *IEEE Trans. Smart Grid*, vol. 8, no. 1, pp. 353–361, 2017.
- [11] J. Yan, C. Li, and Y. Liu, "Adaptive load shedding method based on power imbalance estimated by ANN," in *TENCON 2017 - 2017 IEEE Region 10 Conference*, 2017, vol. 2017-Decem, pp. 2996–2999.
- [12] A. Drabandsari and T. Amraee, "Optimal Setting of Under Frequency Load Shedding Relays in Low Inertia Networks," in *2018 Smart Grid Conference (SGC)*, 2018, pp. 1–6.
- [13] Z. Jianjun, S. Dongyu, Z. Dong, and G. Yang, "Load Shedding Control Strategy for Power System Based on the System Frequency and Voltage Stability(Apr 2018)," in *2018 China International Conference on Electricity Distribution (CICED)*, 2018, no. 201804230000057, pp. 1352–1355.
- [14] V. A. Lytvynchuk, M. I. Kaplin, and N. P. Bolotnyi, "The Method of Design an Optimal Under-Frequency Load Shedding Scheme," *2019 IEEE 6th Int. Conf. Energy Smart Syst. ESS 2019 - Proc.*, vol. 1, pp. 14–17, 2019.
- [15] Y. Y. Hong and P. H. Chen, "Genetic-based underfrequency load shedding in a stand-alone power system considering fuzzy loads," *IEEE Trans. Power Deliv.*, vol. 27, no. 1, pp. 87–95, Jan. 2012.
- [16] M. A. Pai, *Energy Function Analysis for Power System Stability*. Springer US, 1989.
- [17] P. Wall, F. Gonzalez-Longatt, and V. Terzija, "Estimation of generator inertia available during a disturbance," in *IEEE Power and Energy Society General Meeting 2012*, 2012, pp. 1–8.
- [18] "PRC-006-SERC-02:Automatic Underfrequency Load Shedding Requirements - NERCpedia." [Online]. Available: <https://necpedia.com/active-standards/prc-006-serc-02automatic-underfrequency-load-shedding-requirements/>. [Accessed: 25-Jan-2020].
- [19] H. Seyedi and M. Sanaye-Pasand, "Design of New Load Shedding Special Protection Schemes for a Double Area Power System," *Am. J. Appl. Sci.*, vol. 6, no. 2, pp. 317–327, Feb. 2009.